

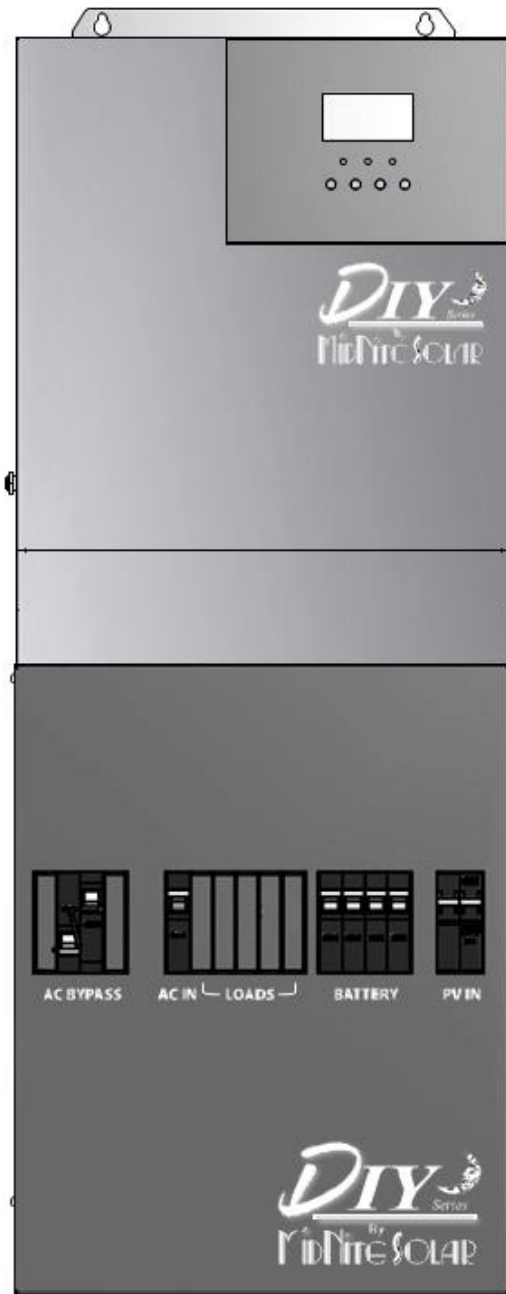

MNE200DIY-120S Manual

DIY E-Panel Owner's Manual





MNE200DIY-120S Manual

Table of Contents

| | |
|--|-----------|
| Introduction | 3 |
| Safety Instructions | 4 |
| Safety Precautions | 5 |
| Battery Safety | 5 |
| How to KILL Your Batteries | 6 |
| How an Inverter / Charger Works | 7 |
| Wiring Requirements | 8 |
| DC Wiring & Over-Current Protection..... | 8 |
| AC Wiring & Over-Current Protection..... | 10 |
| Grounding Requirements | 11 |
| Installation | 13 |
| Location Considerations..... | 13 |
| Knockout Prep Info..... | 15 |
| Mounting Procedures..... | 15 |
| Wiring the DIY Inverter & DIY E-Panel | 17 |
| Ground Wiring..... | 17 |
| AC Kit | 19 |
| Batt Kit..... | 21 |
| PV Kit | 22 |
| SPD Wiring..... | 22 |
| External Wiring..... | 23 |
| Energizing the DIY Inverter & DIY E-Panel | 25 |
| Technical Drawings | 28 |
| Warranty | 33 |

This entire manual is printed without color but is available for download—with many of the diagrams available in color—on our website at midnitesolar.com.



MNE200DIY-120S Manual

INTRODUCTION

The DIY E-Panel enclosure from MidNite Solar provides AC and DC over-current protection and disconnects required for an NEC compliant, renewable energy system. The **MNE200DIY-120S E-Panel** is specifically designed to accommodate the **DIY MN3024DIY inverter**.

This manual does not provide brand specific information about photovoltaic panels, batteries, et cetera. Contact the manufacturer of other components in the system for relevant technical data.

The **DIY E-Panel** includes the following:

- AC input disconnect and an inverter bypass switch.
 - The AC disconnect removes the incoming AC power to the inverter input.
 - The inverter bypass switch easily re-routes the incoming AC power around the inverter and directly to the AC loads in the system, without rewiring or losing power to the AC loads.
- DC breaker to disconnect the battery bank from the inverter as required by the National Electric Code (NEC).
 - Acts as an over-current protection (OCP) device to protect against extremely high currents that a battery can produce, if any short circuits occur.
- Powder-coated steel chassis with knockouts to accommodate multiple lightening surge arrestors (SPD) and conduit wiring.
- AC Neutral, AC IN/OUT busbars; DC+/DC-, PV+/PV-, and Ground busbars.
- DIN rail space for up to five AC branch circuit breakers.
- Mates together with the DIY Inverter.
- PV input disconnect and OCP device.

NOTE: Check page 28 for items included in the DIY E-Panel. Contact MidNite Tech Support if any items are missing.
360.403.7207

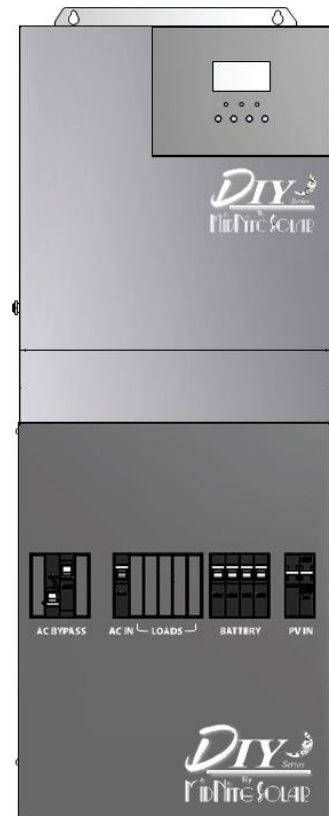



MNE200DIY-120S Manual

IMPORTANT SAFETY INSTRUCTIONS SAVE THESE INSTRUCTIONS

THIS MANUAL CONTAINS IMPORTANT INSTRUCTIONS FOR THE MIDNITE SOLAR MNE200DIY-120S DIY E-PANEL THAT SHALL BE FOLLOWED DURING INSTALLATION AND OPERATION.

If you do not fully understand any of the concepts, terminology, or hazards outlined in these instructions, please refer installation to a qualified dealer, electrician, or installer. These instructions are not meant to be a complete explanation of a renewable energy system. Before using the DIY E-Panel, read all instructions and cautionary markings. The installation instructions are for use by qualified personnel only. Do not perform any installation other than that specified in this manual unless you are qualified to do so. Incorrect installation may result in a risk of electric shock, fire, or other safety hazard.

Safety Symbols

The following safety symbols have been placed throughout this manual to indicate dangerous and important safety instructions.

WARNING!

WARNING indicates a hazardous situation which, if not avoided, could result in death or serious injury.

CAUTION!

CAUTION indicates conditions or practices that could result in damage to the unit or other equipment.

INFO: Indicates information that emphasizes or supplements important points of the main text.

SAFETY PRECAUTIONS

- Live power may be present at more than one point since an inverter utilizes both DC (batteries) and AC (utility or generator) power. To reduce risk of electric shock, ensure all



MNE200DIY-120S Manual

DC and AC wiring is disconnected prior to installing or performing maintenance on the inverter. Turning off the inverter will **NOT** reduce this risk; the inverter must be totally disconnected from all sources.

- Over-current protection for the AC & DC wiring is not provided as an integral part of the DIY inverter. Over-current protection of the AC & DC wiring must be provided as part of the system installation.
- The AC output neutral conductor and the DC negative conductors are not connected (bonded) to the inverter chassis. Both the input and output conductors are isolated from the enclosure and each other.
- System grounding is the responsibility of the system installer and must comply with local and national electrical codes and standards.
- This product is designed for indoor/compartment installation. It must not be exposed to rain, snow, moisture, or liquids of any type.
- Listed or labeled equipment shall be installed and used in accordance with any instructions included in the listing or labeling.
- All electrical work must be performed in accordance with local and national electrical codes.
- Use Class 1 wiring methods for field wiring connections to terminals of a Class 2 circuit.
- Use insulated tools to reduce the chance of electrical shock or accidental short circuits.
- Torque all wiring and cable connections to the required torque values.
- Use only copper wires with a minimum temperature rating of 90°C.
- Always verify proper wiring prior to starting the inverter.
- Battery cables should be no less than #2 AWG.
- The inverter must be properly mounted.

BATTERY SAFETY

- Wear eye protection and avoid touching your eyes and face when working with batteries to keep any fluid/corrosion on the battery from contact with eyes and skin. Have plenty of fresh water and soap nearby and thoroughly wash in case battery acid contacts skin, clothing, or eyes. In the event of exposure to the eyes, flood them for at least 15 minutes with running water and seek immediate medical attention. Baking soda neutralizes lead acid battery electrolyte and vinegar neutralizes spilled NiCad and NiFe battery electrolyte; depending on your battery type, keep a supply on hand near the batteries.
- Read and follow the battery manufacturer's safety precautions before installing the inverter and batteries. Always verify proper polarity and voltage before connecting the batteries to the inverter. Once the batteries are connected to the inverter, ensure the maintenance and charging requirements (i.e., charge voltage and charge rate) provided by the battery



MNE200DIY-120S Manual

manufacturer are followed to extend the life of the batteries and to prevent damage to the batteries while charging.

- The battery bank should be installed in a clean, dry, ventilated environment that is protected from high and low temperatures. If installed in a vehicle/boat, the batteries must be mounted upright (if using liquid batteries) and securely fastened. The location must be fully accessible and protected from exposure to heat producing devices, and away from any fuel tanks.
- Batteries can produce explosive gasses, so install batteries in a well-ventilated area. For compartment or enclosure installations, always vent batteries from the highest point to the outside. Design the battery enclosure to prevent accumulation and concentration of hydrogen gas in pockets at the top of the compartment.
- Remove all jewelry such as rings, watches, bracelets, etc., when installing or performing maintenance on the batteries and inverter. A battery can produce a short-circuit current high enough to weld metal jewelry, causing severe burns.
- Use insulated tools and be very careful when working around batteries, they can produce extremely high currents if short-circuited (e.g., dropping a metal tool across the battery terminal), which could cause a fire or explosion.
- To prevent a spark at the battery and to reduce the chance of explosion, always connect the cables to the batteries first. Then connect the cables to the inverter.
- Never use old or untested batteries. Check each battery's label for age, type, and date code to ensure all batteries are identical.
- Batteries are sensitive to changes in temperature. Install batteries in a stable environment.
- Provide at least one inch of air space between batteries to provide optimum cooling.
- Never smoke or allow a spark near batteries.
- Never charge a frozen battery.

HOW TO **KILL** YOUR BATTERIES

Batteries are delicate and require proper attention, especially when off-grid. Think of your batteries and solar equipment as a small nuclear power plant, hydro dam, or natural gas-fired power plant. Just like any of those, your system needs DAILY attention to ensure it is performing correctly and safely. We recommend the use of an independent battery monitor/alarm if you have an expensive battery bank. Below is a list of some of the most common ways we have seen people kill their battery bank.

- Using more than three parallel strings and not using common bus bars. With lead-acid batteries, when you use more than three strings, it is very hard to properly charge the middle strings. The only safe way to do this is to wire each string with equal length cables to a common bus bar. Connect inverter cables to the farthest points on the busbars.



MNE200DIY-120S Manual

- Not watching to verify the Absorb or EQ times are set properly and that the equipment actually charges for that period of time. Some equipment will have settings like “End Amps” that can terminate Absorb early and, if set up wrong, can damage a battery.
- Not using ALL EQUAL LENGTH interconnect cables on each string. It is important that ALL strings be wired EXACTLY the same. Any variance in resistance on one string versus another will cause an imbalance and the batteries will suffer a shortened lifespan.
- Trusting a State of Charge (SOC) meter, which can lose calibration over time and give you false readings. You need to verify specific gravity and or verify the charge voltage is being met. Never fully rely on the SOC %; it is just a good, quick reference.
- Routinely using more than 50% of the capacity of the lead acid battery. Using more than half the battery capacity drastically shortens the batteries life; occasionally is fine, but daily will kill lead acid batteries in months.
- Not leaving ample space between cells for cooling. We recommend at least one inch between the cells for cooling. Ask the battery manufacturer what they recommend.
- Not having enough charge current to properly charge the size of the battery you have. Consult the battery manufacturer for the minimum charge current.
- Using tap water or other liquids instead of distilled water in a flooded battery. The minerals in the tap water will destroy a battery.
- Not verifying the temperature compensation neutral point (typically 25°C) and the milli volts per degree C per cell (typically -5mV).
- Not verifying you are charging to the voltage supplied by the battery manufacturer.
- Not fully charging your lead acid batteries at least once a week.
- Failing to keep all connections clean.

WARNING!

Verify correct polarity with a multimeter **BEFORE** connecting the battery cables to the DIY E-Panel.

HOW AN INVERTER/CHARGER WORKS

Inverter Mode

When an inverter is properly connected to batteries and turned on, the direct current (DC) from the batteries is transformed into a pure sine wave alternating current (AC). This AC is similar to the voltage provided by your utility and is used to power electrical appliances (AC loads) connected to the inverter’s output.



MNE200DIY-120S Manual

Standby (Charger) Mode

When an external source of AC power (utility or generator) is connected and qualified on the inverter's AC input, the inverter then operates in Standby mode. The inverter operates as a battery charger to convert the AC IN power into DC OUT power to recharge the batteries; at the same time, the inverter automatically closes an internal AC transfer relay to pass the incoming AC power directly to the inverter's output to continue powering the connected AC loads.

WIRING REQUIREMENTS

- The NEC (National Electric Code, ANSI/NFPA 70) for the United States and the CEC (Canadian Electrical Code) for Canada provide standards for safely wiring residential and commercial installations. The NEC/CEC lists the requirements for wire size, over-current protection, and installation methods.
- Do not mix AC and DC wiring in the same panel unless specifically approved/designed for both AC and DC wiring. Where DC wiring must cross AC or vice-versa, try to make the wires at the crossing point perpendicular (90 degrees) to one another.
- AC and DC wires to and from the inverter must be protected as required by code. This can be done by using jacketed wires or by feeding the wires through conduit or a conduit box.
- Always check for existing electrical, plumbing, or other areas of potential damage prior to making cuts in structural surfaces or walls.
- The inverter requires a reliable negative and ground return path directly to the battery.
- Both AC and DC over-current protection must be provided as part of the installation.
- Use only copper wires with a minimum temperature rating of 90°C.
- The equipment ground is marked with this symbol: 

WARNING!

In most electrical systems, the neutral-to-ground bond is located in the main utility service entrance panel. Remove any bond downstream from the inverter to prevent multiple bonds. If there is an inverter sub-panel—separate from a main electrical panel—it should have a removable wire that allows the neutral bus to be unbonded from the ground busbar.

DC Wiring

- Minimize the number of connections between the DIY inverter and the battery bank. Exceptions are the DC breaker —required at the battery to protect the DC wiring—in the



MNE200DIY-120S Manual

positive line, and a DC shunt—to allow battery charge state monitoring—in the negative line. Additional connections will contribute to voltage drops, and these extra connection points may loosen during use.

- DC cables should be tied together with wire ties or electrical tape approximately every 6". This helps improve the surge capability and reduces the effects of inductance, which improves the inverter waveform and reduces wear of the inverter's filter capacitors.
- All wiring to the battery terminals should be checked monthly for proper torque/tightness. If you don't have a torque wrench, ensure all DC terminals are tight and cannot move.
- The DC cables/wires must be color coded with colored tape or heat shrink tubing: RED for positive (+); WHITE for negative (-) if solidly grounded or BLACK if using a GFP breaker; and GREEN for DC ground.
- Use the correct DC cable and corresponding circuit breaker to achieve maximum efficiency from the system and reduce fire hazards associated with overheating.
- The DC cables must be fine strand, super flexible, such as Cobra cable (or equivalent) and be approved for residential wiring per the NEC (THW for example).
- Do not use the inverter's chassis in place of the battery negative connection for grounding. The inverter requires a reliable return path directly to the battery.
- The DC busbars in the DIY E-Panel have dual sizes. The smaller nine holes accept #6 to #14 AWG wire and the larger two holes accept up to #1/0 AWG.
- A readily accessible battery disconnect is required and must be located within sight of the battery system (NEC 480.7). The DIY E-Panel provides this.
- The **200A** DC Inverter Battery breaker and Batt- busbar have studs that require cables with 5/16" terminal lugs.
- Ensure cables have a smooth bend radius and do not become kinked.
- Ensure both DC cables pass through the same knockout and conduit to allow the inductive currents to cancel.
- Limit cable length to 6' or less from DIY E-Panel to battery bank.
- **The nominal battery bank voltage MUST be 24V!**

DC Over-Current Protection

- The NEC requires both over-current protection (UL489 standards) and a disconnect switch. If a circuit breaker is used as the over-current protection device, it can also be used as the required DC disconnect.
- The DC over-current protection device must be installed on the positive DC cable and it must be correctly sized according to the size of DC cables being used.



MNE200DIY-120S Manual

AC Wiring

- When wiring the AC input and output circuits, we recommend a full system Inverter Bypass Switch, which provides a convenient means to isolate the inverter for battery maintenance and to continuously power AC loads without any re-wiring.
- The wire sizes recommended in this manual are based on the ampacities given in Table 310.17 (in free air) of the NEC, ANSI/NFPA 70, for 75°C (167°F) copper wire based on an ambient temperature of 30°C (86°F).
- Always use properly rated circuit breakers. If using an electrical sub-panel, circuit breakers can be moved from the main electrical panel to the sub-panel only if the breakers are also listed to be installed in the sub-panel.
- The AC wiring must be protected from short circuits and overloads by an over-current protection device (UL1077 standards) and have a means to disconnect the AC circuits.
- AC busbars (for neutral and hot) in the DIY E-Panel have dual sizes. The smaller nine holes accept #6 to #14 AWG wire and the larger two holes accept up to #1/0 AWG.
- An AC generator wired into the DIY inverter must have an emergency shutdown device located outside the dwelling at a readily accessible location (NEC 445.18).
- **DO NOT** connect the inverter's output to an external AC power source. This could cause severe damage to the inverter and is not covered under warranty.
- AC loads powered by the inverter will need to be installed into an electrical sub-panel with branch breakers to power the AC loads.
- The AC IN and OUT neutrals are common and may be wired to a common neutral bus.
- Use **#8 AWG**, 600V wire for the AC IN and AC OUT wires.

CAUTION!

- AC wiring must be no smaller than **#8 AWG** gauge copper wire.
- The inverter's internal AC transfer relay is rated at **40A**. The pass-through current cannot exceed **40A** or damage to the relay will occur.

AC Ground Fault Circuit Interruption (GFCI)

UL standards require the use of GFCI outlets or breakers on the AC output of an inverter.

WARNING!

RISK OF ELECTRIC SHOCK! Use only ground-fault circuit interrupters--receptacle(s) or circuit breaker(s)--compatible with your inverter/charger.



MNE200DIY-120S Manual

AC Over-Current Protection

- Over-current protection for power-feeder conductors from the inverter shall be within seven inches of the output connections or may be within 40 inches of the output connections if the unprotected insulated conductors are contained throughout their entire distance in a sheath or enclosure such as a conduit/junction box or enclosed panel.
- The full AC continuous pass-thru capacity of the DIY inverter/charger is limited to **40A**. AC IN to the inverter requires a **40A** continuous duty rated breaker, which corresponds to a minimum cable size of **#8 AWG**. AC OUT requires a **40A** breaker.
- The AC over-current protection device must be a circuit breaker or a fuse/disconnect and be properly sized and branch circuit rated for the wire it is protecting and the appliances being powered.

CAUTION!

- The DIY inverter may be used in a negative grounded installation. For a grounded system, bond Battery Negative to Ground.
- The DIY inverter is **NOT** intended for use with life support equipment or other medical equipment or devices.

Arc Fault - The NEC requires any PV system DC circuit operating at 80VDC or greater must be protected by an arc fault (AF) circuit interrupter.

Ground Fault - Since 2008 the NEC requires a DC Ground Fault (GF) Protection device on all PV systems to indicate when a GF condition exists.

GROUNDING REQUIREMENTS

- Proper grounding is critically important for several reasons:
 - Ensures voltages present throughout the system are all at the same ground reference point.
 - Adheres to National Electrical Code (NEC) requirements.
 - Safety – ensures all metal components are touch-safe.
 - Allows stray current a return path to its source.
- The DIY inverter has two separate electrical systems – AC and DC; therefore, each electrical system is required to be connected to a permanent, common, ground or earth reference.
- There are two types of grounding:



MNE200DIY-120S Manual

- **Equipment Grounding** – Grounding for exposed metal parts, like the inverter chassis, solar panel frames, etc.
- **System Grounding** – The bonding of a current-carrying wire to earth ground, such as a Neutral-to-Ground bond (AC), or Batt- bonded to ground (DC).
- The NEC assigns specific names to the various parts of a grounding system:
 - **Grounded Conductor (GC)** – A current-carrying wire (AC Neutral or DC Negative) that is connected or “bonded” to ground.
 - **Equipment Grounding Conductor (EGC)** – A wire or cable that does not carry current and connects exposed equipment metal to earth ground (Grounding Electrode).
 - **Grounding Electrode Conductor (GEC)** – A wire or cable that does not carry current and connects the Grounding Electrode (GE; ground rod) to the Grounded Conductor (GC) and the Equipment Grounding Conductor (EGC).
 - **Grounding Electrode (GE)** – ground rod.
 - **System Bonding Jumper (SBJ)** – The connection between the Grounded Conductor (GC) and the Equipment Grounding Conductor (EGC).
- These different ground wires are sized: 1) Based on how the overall system is wired together; 2) The number of ground electrodes (ground rods); and 3) The size of the largest current-carrying wire (both AC and DC factor in).

DIY Inverter & DIY E-Panel Grounding

- The easiest grounding installation with the DIY inverter and DIY E-Panel is shown below in **Figure 1**. The reason it is easiest is that the entire system is bonded together at the same ground busbar inside the DIY E-Panel **AND** there is only one ground rod.
- MidNite has selected the correct wire gauge inside the DIY E-Panel for all the different ground connections mentioned above. But the exception is the Grounding Electrode Conductor (GEC). If you wire your new DIY E-Panel using either configuration as shown below in **Figures 1 & 2**, then use **#6 AWG** wire. Simple as that!
 - If you deviate from this recommended ground wire method, you must consult the determine the correct GEC wire

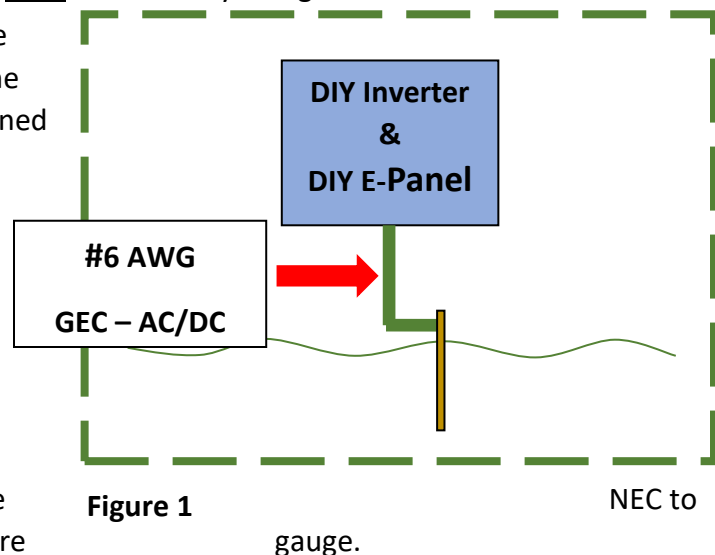

Configuration #1 - Using the DIY E-Panel as the AC service panel (**Figure 1**).

- All the required ground wires are contained within the DIY E-Panel.
- The DIY E-Panel serves as the only AC service panel for the off-grid application.
- The DIY E-Panel has DIN rail space for 5 AC branch circuit breakers.

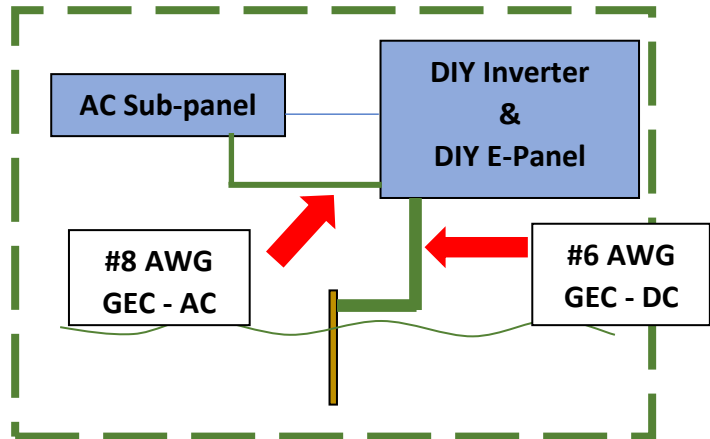

Figure 2

- Bond DIY E-Panel Ground busbar to ground rod with **#6 AWG** wire for GEC-AC/DC.

Configuration #2 - Using a separate AC sub-panel (**Figure 2**).

- Using an existing AC sub-panel. The DIY E-Panel AC OUT feeds this existing AC sub-panel.
- Bond the AC sub-panel to the Ground busbar in the DIY E-Panel with **#8 AWG** ground wire. This connection is called the Grounding Electrode Conductor (GEC) for the AC side of the system (GEC-AC).
- Bond DIY E-Panel Ground busbar to ground rod with **#6 AWG** wire for GEC-DC.

INSTALLATION

Before installing, read the entire installation section to determine how you are going to install the DIY inverter and DIY E-Panel. The more thoroughly you plan in the beginning, the better your overall system needs will be met.

Location Considerations

- Locate the DIY E-Panel as close to the batteries as possible. Long DC wires tend to lose efficiency and reduce the overall performance of an inverter. Do not mount where it will be exposed to gases produced by the batteries. Gases are corrosive and will damage the inverter; also, if these gases are not ventilated and if allowed to collect, they could ignite and cause an explosion.
- The NEC requires 30" clear on the wall. The DIY E-Panel may be located anywhere within this 30". The NEC also requires 36" free and clear of obstructions in front of the charge controller. The 36" clear area in front of all electrical panels is to provide a space to fall



MNE200DIY-120S Manual

back into in case of electrical shock.

- The area must be free from any risk of condensation, water, or any other liquid that can enter or fall on the inverter. The DIY inverter and DIY E-Panel is indoor rated and should not be placed outside unless precautions are made to keep rain and moisture off the system.
- Ensure the DIY inverter is accessible after it is mounted. The inverter is programmed and data points monitored via an LCD screen and pushbuttons on the front panel. You will need to access the inverter's front panel during and after installation.
- Keep any flammable/combustible material (e.g., paper, cloth, plastic, etc.) that may be ignited by heat, sparks, or flames at a minimum distance of 2' away from the inverter.
- Do not mount this inverter in a zero-clearance compartment, nor cover or obstruct the ventilation openings—overheating may result. Fresh air intake is required!
- The DIY inverter and DIY E-panel combined weighs 25 pounds. The mounting surface and hardware must be capable of supporting at least twice the weight.
- The DIY inverter and DIY E-Panel should not be installed in an area that allows dust, fumes, insects, or rodents to enter or block the ventilation openings.
- The DIY inverter and DIY E-Panel should be protected from direct sun exposure or equipment that produces extreme heat.
- Plan any conduit runs now. Typical wiring and routing examples:
 - AC IN from grid or generator or transfer switch
 - AC OUT to service or sub-panel
 - DC cables to battery bank
- Mounted vertically on a flat, **non-combustible** surface.

Installations should be performed by a licensed or certified electrician. It is the installer's responsibility to determine which safety codes apply and to ensure that all applicable installation requirements are followed.

CAUTION!

The DIY E-Panel is designed for indoor installation or installation inside a weatherproof enclosure. It must not be exposed to rain and should be installed out of direct sunlight.

WARNING!

The DIY inverter is not ignition-protected. Do not install in any area that contains extremely flammable liquids like gasoline or propane.



MNE200DIY-120S Manual

Knockout Prep Info

See technical drawing on page 29 for the location and dimensions of the knockouts on the DIY E-Panel. Think about all the different wiring required and remove the appropriate knockouts before mounting the DIY E-Panel.

Determine the knockout uses for:

- Wiring from the DIY E-Panel to an AC electrical panel;
- Wire runs from grid and/or a generator to the DIY E-Panel;
- Battery cable wiring from the battery bank to the DIY E-Panel;
- Attaching lightning arrestors (SPD).

Remove designated knockouts now using a flat bladed screwdriver and a hammer. Hold the DIY E-Panel firmly on a workbench, leave area at bottom for the knockout to move.

The DIY E-Panel metal is thin. Take care not to deform metal surrounding the knockouts!

Mounting Procedures:

- Wire up the DIY E-Panel **BEFORE** mounting to the wall! Wiring instructions on page 18.
- With your DIY E-panel completely wired and your mounting location selected, secure and level the DIY E-Panel to the mounting surface using appropriate mounting hardware.
- Now align the DIY inverter above the DIY E-panel, watch for the wires coming out of the top of the E-panel. Mate the two units together. Secure the DIY inverter to the wall with appropriate hardware.
 - The inverter has two mounting holes located on the flange at the top of the inverter and a third hole in the bottom area of the inverter.
- You can mate together the DIY E-Panel to the DIY inverter if you want, to make one complete assembly. Do this prior to installation. The inverter and E-panel do not have pre-drilled holes to accomplish this. Mate the units together, drill holes, and lock together with bolts and nuts.

It is easier to wire the DIY E-Panel while it is lying horizontal on a table. Do as much as possible before mounting the E-Panel on the wall.

Figure 3 shows the DIY System as wired. Take a moment to review this system diagram. Notice the different circuit breakers, busbars, inverter terminal blocks, and the flow of the wiring.

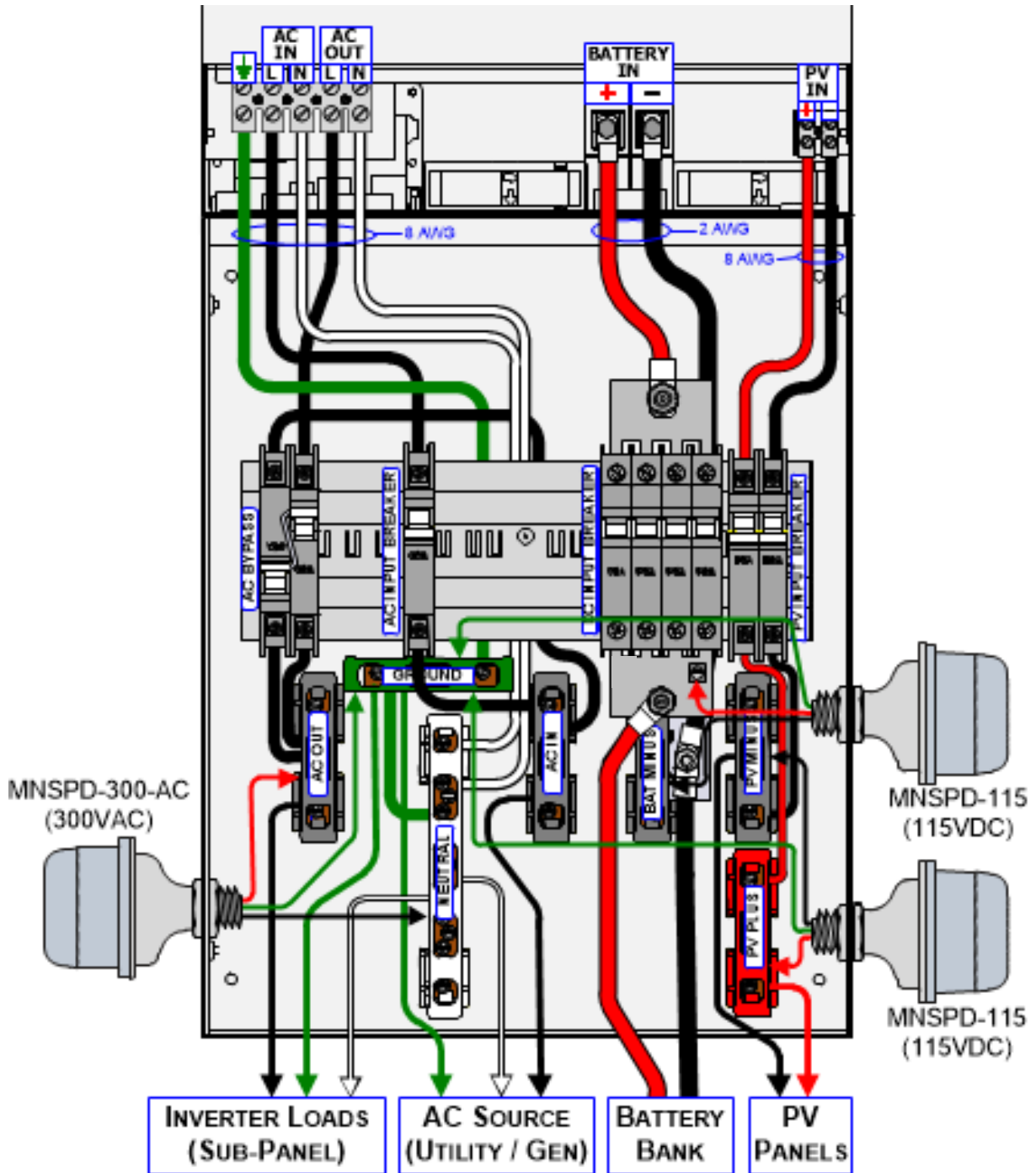

Figure 3



MNE200DIY-120S Manual

WIRING THE DIY INVERTER & DIY E-PANEL

The DIY E-Panel has 3 parts kits inside, labeled **AC KIT**, **DC KIT**, and **PV KIT**. It is easiest to wire the DIY E-Panel kit-by-kit. Reference **Figure 5** on next page. Notice how the DIY E-Panel is divided into 3 sections based on the 3 parts kits.

Reference wire drawings on pages 30-32. These drawings show the individual wires in each parts kit, and the wiring designations. Wiring the DIY E-Panel is easy when the wires are installed number by number. To explain the wire designation system, look at the BATT wire example below ...

BAT 01-2R

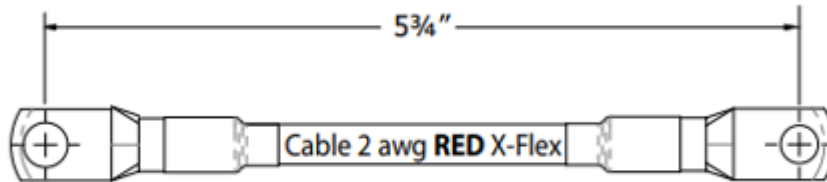

“BAT 01-2R” indicates ...

“BAT” = Battery breaker wire

“01” = Wire #1

“2R” = #2 AWG red

Ground Wiring (Figure 4)

#1 / #3 - Connect green ground wire “AC-01-8G” between DIY Inverter AC IN ground terminal and Ground busbar.

#2 / #3 - Connect green ground wire “AC-09-8G” between Neutral busbar and Ground busbar. **ONLY** make **ONE** Neutral-to-Ground bond in the entire system!

Torque all set screws.

The DIY Inverter offers two AC Ground terminals, only one needs to be bonded to the Ground busbar. The ground screw on bottom of DIY inverter is common to the AC ground and does not need to be bonded.

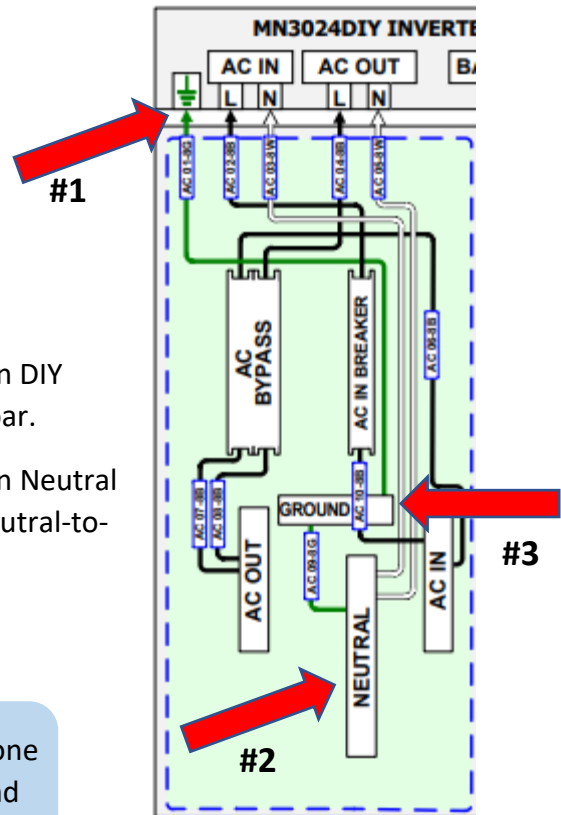

Figure 4

MNE200DIY-120S KIT INSTALL AREA MAP

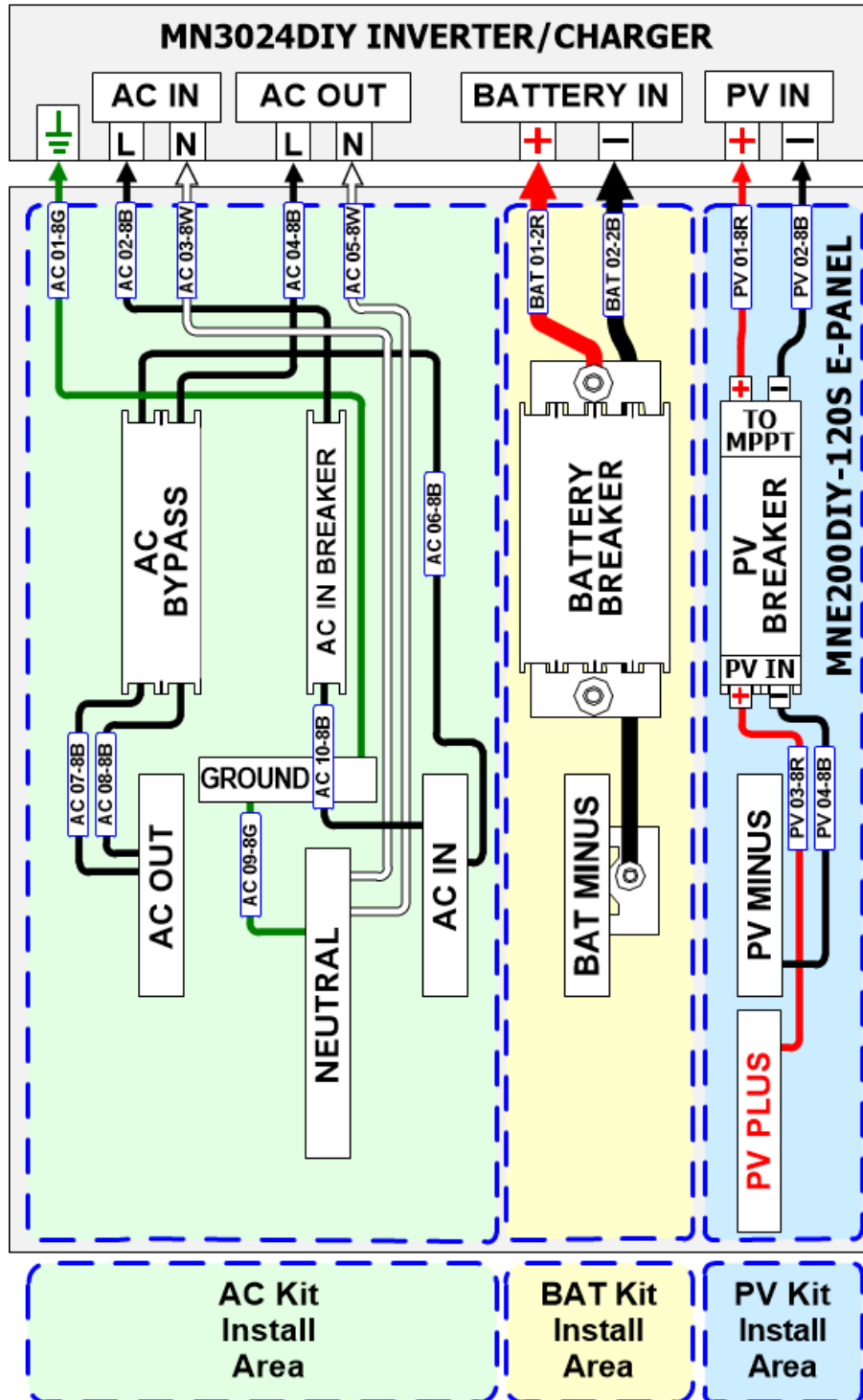

Figure 5

WARNING!

Ensure all sources of DC power (i.e., batteries, solar, wind, or hydro) and AC power (utility or AC generator) are de-energized (i.e., breakers opened, fuses removed) before proceeding—to prevent accidental shock.

AC KIT

Install AC Breakers (Figure 6)

Locate the AC breakers and wires in the **AC KIT** and install as follows:

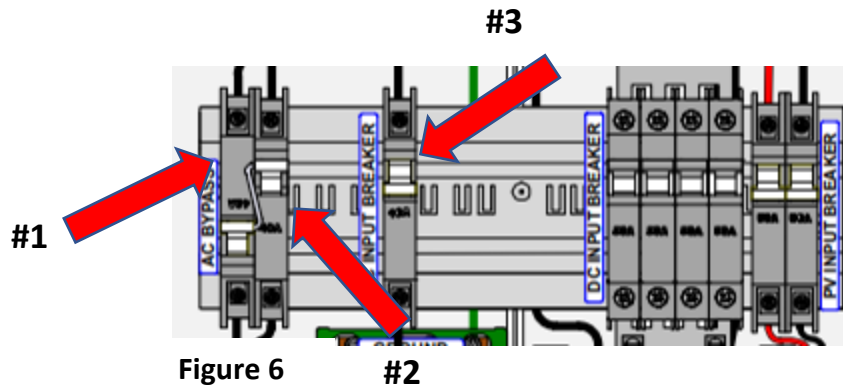

#1 – AC Bypass breaker, **40A**. Flick out yellow lock-tab. Install it upside down. The breaker mounts on the DIN rail from the top, then the bottom. Since this breaker is upside-down, attach the “bottom” of breaker to the DIN rail, then the “top.” Leave yellow lock-tab out (unlocked) for now.

#2 – AC OUT breaker, **40A**. Install it right-side up. Attach the Z-clip between the two AC breakers. Leave lock-tab out for now.

#3 – AC IN breaker, **40A**. Install it right-side up. Leave yellow lock-tab out for now.

Align AC Breakers (Figure 7)

Align the DIY E-Panel front cover to the chassis, seeing if the installed AC breakers are positioned correctly on the DIN rail relative to the openings. Move the breakers as required. Push-in the yellow lock-tabs on all 3 AC breakers.

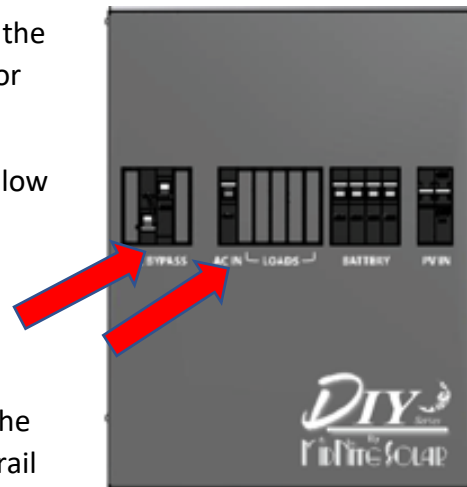

Figure 7



MNE200DIY-120S Manual

AC Wiring (Figure 8)

#1 / #6 - Connect black wire “AC-02-8B” at top of AC IN breaker to DIY Inverter AC IN.

#1 / #4 - Connect white wire “AC-03-8W” to DIY Inverter AC IN Neutral terminal and to Neutral busbar.

#2 / #7 - Connect black wire “AC-04-8B” at top of right-AC OUT breaker to DIY Inverter AC OUT.

#4 / #7 - Connect white wire “AC-05-8W” to DIY Inverter AC OUT Neutral terminal and to Neutral busbar.

#2 / #5 - Connect black wire “AC-06-8B” at AC IN busbar to top of left-side AC Bypass breaker.

#2 / #3 - Connect black wire “AC-07-8B” at AC OUT busbar to bottom left-side AC Bypass breaker.

#2 / #3 - Connect black wire “AC-08-8B” at AC OUT busbar to bottom right-side AC OUT breaker.

#5 / #6 - Connect black wire “AC-10-8B” at AC IN busbar to bottom of AC IN breaker.

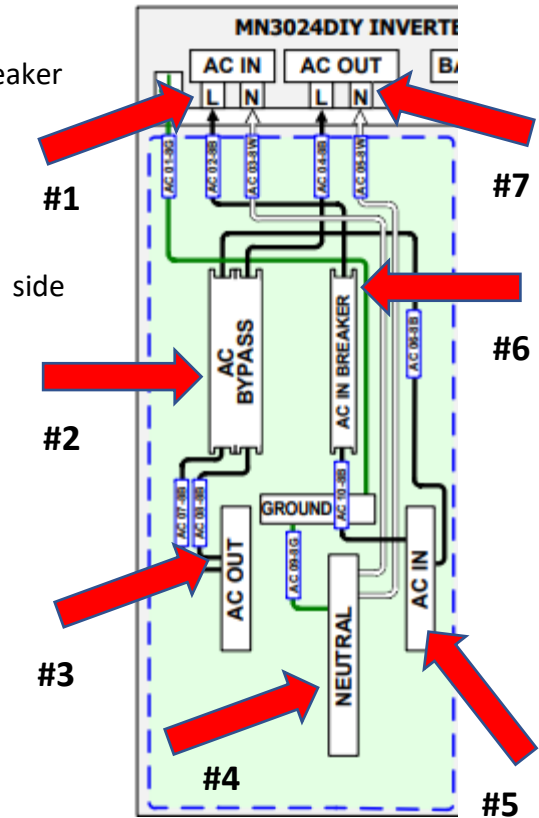

Figure 8

Torque all setscrews (breakers and busbars).

Do NOT connect to AC source.

Route AC wiring through the center opening of the DIN rail.

| TORQUE SPECS | |
|--|--|
| DIY E-Panel | DIY Inverter |
| <p><u>Battery Breaker Studs</u> - 220 in-lbs <u>Batt— Busbar Stud</u> – 220 in-lbs <u>AC/PV Breakers</u> – 20 in-lbs - Small screws, #8 AWG, 25 in-lbs - Small screws, #6 AWG, 35 in-lbs <u>Busbars</u> - Large screws, #8 AWG, 40 in-lbs - Large screws, #4-6 AWG, 45 in-lbs - Large screws. #3-1/0 AWG. 50 in-lbs</p> | <p><u>AC Terminal</u> – 10.6 in-lbs <u>PV Terminal</u> – 7.1 in-lbs <u>Battery Studs</u> – 80 in-lbs</p> |



MNE200DIY-120S Manual

BAT KIT

Install Battery Breaker (Figure 9)

Locate the Battery breaker and wires in the **BAT KIT** and mount the Batt breaker to the DIN rail. Align Batt breaker to the front cover opening. Secure breaker to DIN rail.

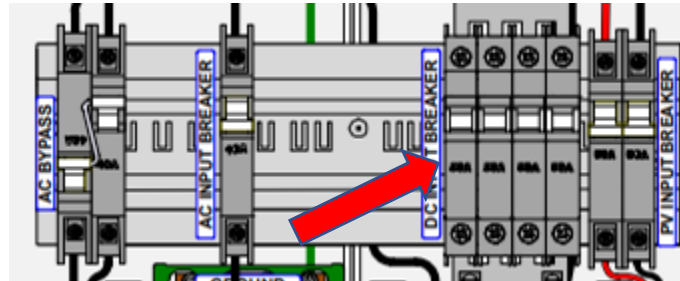

Figure 9

BATT Wiring (Figure 10)

#1 / #2 – Connect red wire “BAT-01-2R” between top bolt of Batt breaker and DIY Inverter Batt+ terminal.

#3 / #4 - Connect black wire “BAT-02-2B” between Batt- busbar and DIY Inverter Batt- terminal.

Torque all bolts.

DO NOT connect battery bank to E-Panel.

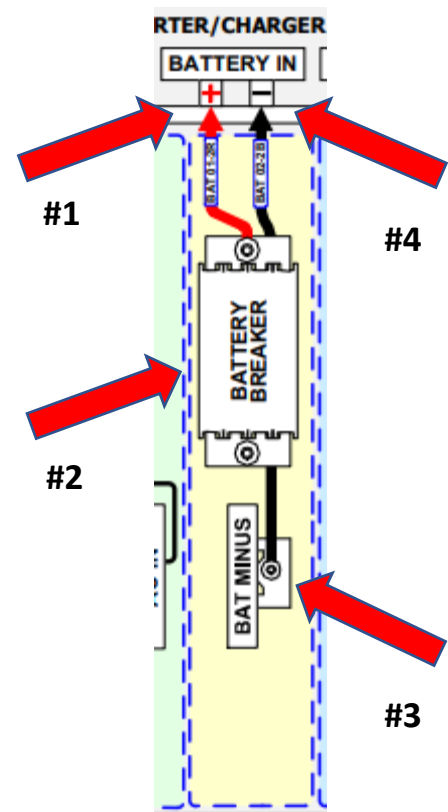

Figure 10

CAUTION!

It is highly recommended to recheck all torques after an hour and conduct a pull test. You may be surprised that what you thought was a tight connection actually pulls out with little effort. Copper is a relatively soft metal and will continue to move under inadequate clamping pressure; a 20-inch pound of torque takes a lot of strength!



MNE200DIY-120S Manual

PV KIT

Install PV Breaker (Figure 11)

Locate the PV breaker and wires in the **PV KIT** and mount the PV breaker to the DIN rail. Align PV breaker to the front cover opening. Secure breaker to DIN rail.

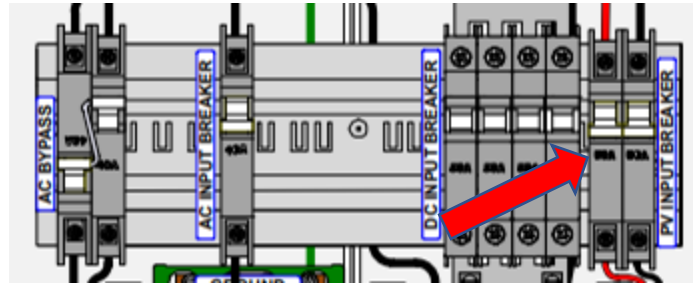

Figure 11

PV Wiring (Figure 12)

#1 / #2 - Connect red wire “PV-01-8R” between top left of PV breaker and DIY Inverter PV+ terminal.

#5 / #6 - Connect black wire “PV-02-8B” between top right of PV breaker and DIY Inverter PV- terminal

#2 / #4 - Connect red wire “PV-03-8R” between bottom left of PV breaker and PV+ busbar.

#3 / #5 - Connect black wire “PV-04-8B” between bottom right of PV breaker and PV- busbar.

Torque all set screws.

NOTE - Ensure copper jumper on PV breaker is removed, if present.

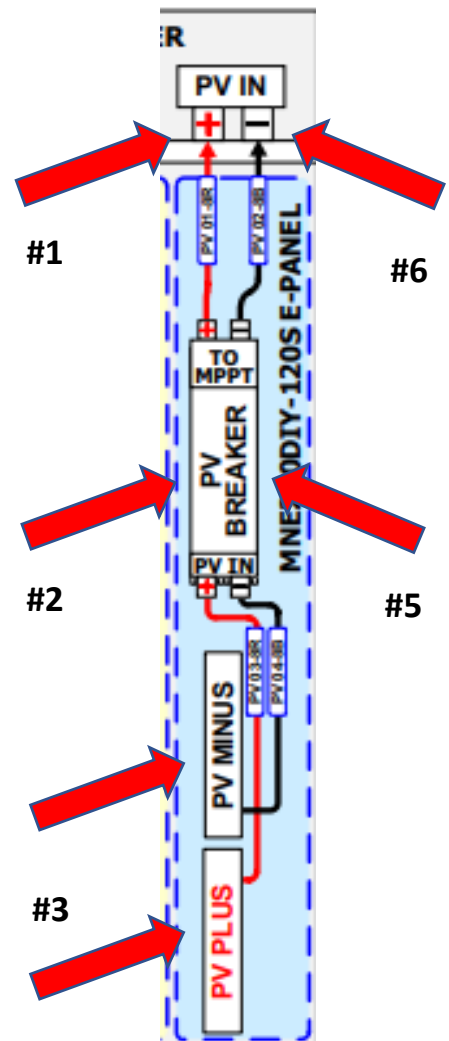

Figure 12

SPD Wiring (Figure 13)

#1 – Install SPD300AC on left side of E-Panel. Connect SPD red wire to AC OUT busbar, SPD black wire to Neutral busbar, OR (if using AC IN), wire the SPD black wire to AC IN busbar, and SPD green wire to Ground busbar.

#2 – Install SPD115 on right side of E-Panel. Connect SPD red wire to PV+ busbar, SPD black wire to PV- busbar, and SPD green wire to Ground busbar.



MNE200DIY-120S Manual

#3 – To protect the BMS on Lithium batteries, install SPD115 on right side of E-Panel. Connect SPD red wire to bottom of Batt breaker, SPD black wire to Batt- busbar, and SPD green wire to Ground busbar

Torque all set screws.

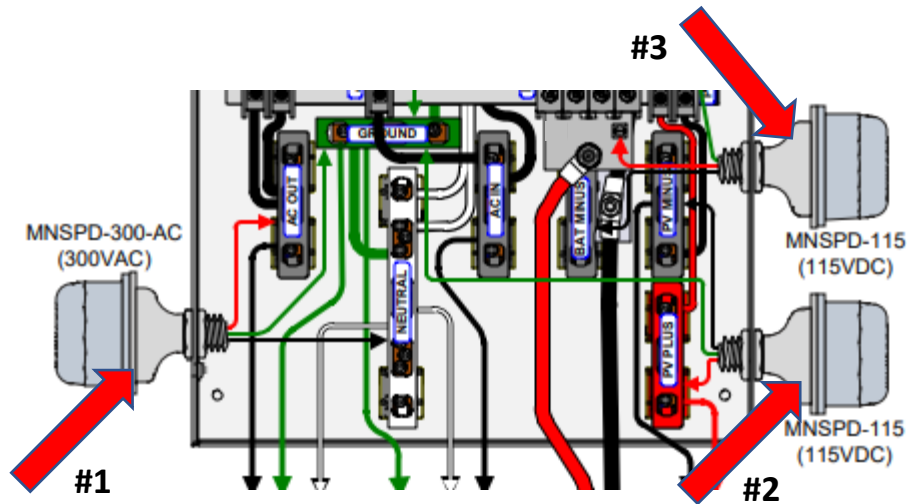

Figure 13

SPD installation is optional but is excellent protection for your system!

UL and the NEC allow mixing AC and DC wiring in this installation because the wire insulation is rated for the highest voltage encountered in the enclosure. Both AC and DC circuits are considered part of the same Renewable Energy circuit for this installation.

EXTERNAL WIRING

External AC Wiring (Figure 14)

NOTE - Ensure all AC breakers are off.

#1 – Connect **#8 AWG** black wire between AC OUT busbar and AC electrical sub-panel.

#2 – Connect **#8 AWG** white wire between Neutral busbar and AC source (genny or grid) **AND** another **#8 AWG** white wire to AC service sub-panel.



MNE200DIY-120S Manual

#3 – Connect #8 AWG black wire between AC IN busbar and AC source (genny or grid).

Torque all set screws.

CAUTION!

Only **ONE** Neutral-to-ground bond can exist in this AC system wiring. Pick a spot: 1) At the AC source; 2) In the DIY System; 3) At the critical load panel (sub-panel).

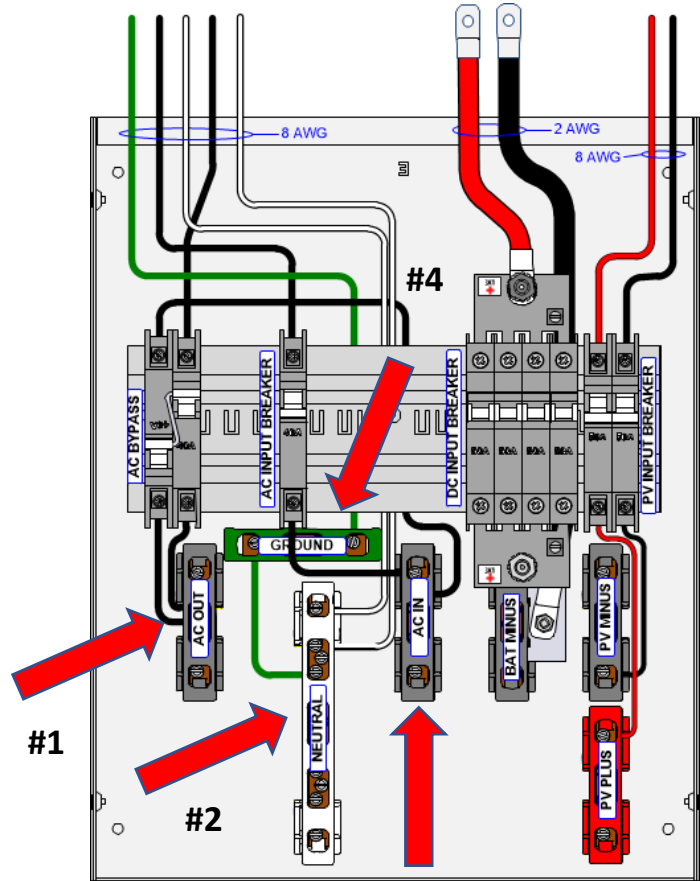

Figure 14

#3

External Ground Wiring (Figure 14)

#4 – Connect #6 AWG wire between Ground busbar and ground rod if wiring the DIY E-Panel in one of the two recommended grounding methods (pages 13 & 14). Otherwise, consult the NEC for proper GEC wire gauge.

External BATT Wiring (Figure 15)

NOTE – Ensure Battery breaker is off.

#1 – Connect #2/0 AWG Batt+ source wire (from batt bank) to the Batt+ stud at bottom of Batt breaker.

#2 – Connect #2/0 AWG Batt- source wire to the Batt- stud on the Batt- busbar.

Torque all nuts.



MNE200DIY-120S Manual

External PV Wiring (Figure 15)

NOTE: Ensure PV breakers are off.

#3 – Connect PV+ source wire to the PV+ busbar.

#4 – Connect PV- source wire to the PV- busbar.

Torque all set screws.

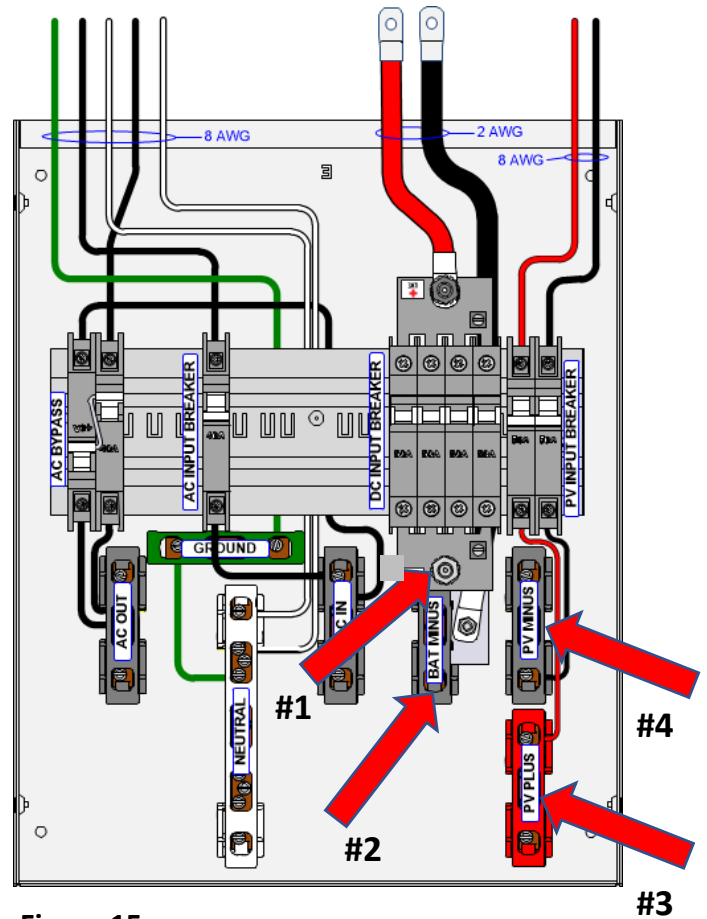

Figure 15

Read the MidNite DIY Manual to learn more about battery banks, PV selection, PV design, PV wiring, PV combining, PV OCP.

www.midnitesolar.com/pdfs/DIY_Manua_Nov__2021.pdf

ENERGIZING THE DIY INVERTER & DIY E-PANEL

Read and follow the information below and the procedural steps listed by number to properly energize and test the DIY Inverter and DIY E-Panel.

- Ensure critical or primary load center is de-energized or disconnected.
- Ensure AC source is de-energized or disconnected.



MNE200DIY-120S Manual

- Ensure all breakers are off.
- You will need an AC/DC voltmeter.

Step #1 - Battery

- **Voltmeter** – Measure for battery bank voltage between the inverter Battery breaker’s DC+ busbar (at bottom of breaker) and the Batt- busbar.
 - Battery bank voltage present (20-33VDC)?
 - **Yes** – Good
 - **No** – Check DC wiring to the battery. Check batteries.
- Close the inverter’s Battery breaker.
- **Voltmeter** – Measure for battery bank voltage between the inverter’s Batt+ and Batt- terminals.
 - Battery bank voltage present?
 - **Yes** – Good
 - **No** – Check DC wiring or battery breaker.

Step #2 - Inverter

- Turn on the AC OUT switch on the DIY Inverter. ON/OFF rocker located on the inverter’s lower right corner, accessible at top of E-Panel.
- Program the DIY Inverter per the inverter’s owner’s manual.

Step #3 - AC

- Turn on AC IN source (grid or genny).
- **Voltmeter** – Measure for 120VAC (+/- 5VAC) between AC IN busbar and AC Neutral busbar.
 - 120VAC present?
 - **Yes** – Good
 - **No** – Check AC source or connections.
- Turn on the AC IN breaker.
- **Voltmeter** – Measure for 120VAC (+/- 5VAC) between inverter’s AC IN terminal and AC Neutral terminal.
 - 120VAC present?
 - **Yes** – Good



MNE200DIY-120S Manual

- **No** – Check breaker or connections.
- Check inverter display via programming buttons for 120VAC (+/- 5VAC) IN at 60Hz. Refer to inverter manual.
- Turn on the AC OUT breaker.
- **Voltmeter** – Measure for 120VAC (+/- 5VAC) between AC OUT busbar and AC Neutral busbar.
 - 120VAC present?
 - **Yes** – Good
 - **No** – Check AC OUT breaker, wiring in between, or inverter programming.
- Move AC Bypass slider to the down (Bypass) position
- **Voltmeter** – Measure for 120VAC (+/- 5VAC) between AC OUT busbar and AC Neutral busbar.
 - 120VAC present?
 - Yes – Good
 - No – Check the Bypass breaker and wiring from AC IN to AC OUT busbars.

Step #4 - PV

- Connect or turn on the PV input (PV combiner).
- **Voltmeter** – Measure for PV voltage (30-100Voc) between PV+ busbar and PV- busbar. **NOTE: Best to wire PV into the 3024DIY at around 70-80Voc. Do NOT wire PV too close to the minimum of 30Voc.**
 - PV voltage (Voc, open-circuit voltage) present?
 - **Yes** – Good
 - **No** – Check PV combiner breakers, PV wiring, or connections.
- Turn on (close) the PV IN breaker.
- **Voltmeter** – Measure for PV voltage between inverter's PV+ and PV- terminals.
 - PV voltage (Voc, open-circuit voltage) present?
 - **Yes** – Good
 - **No** – Check connections, PV IN breaker, wiring.

If the above steps check good, then the DIY System is ready for operation.

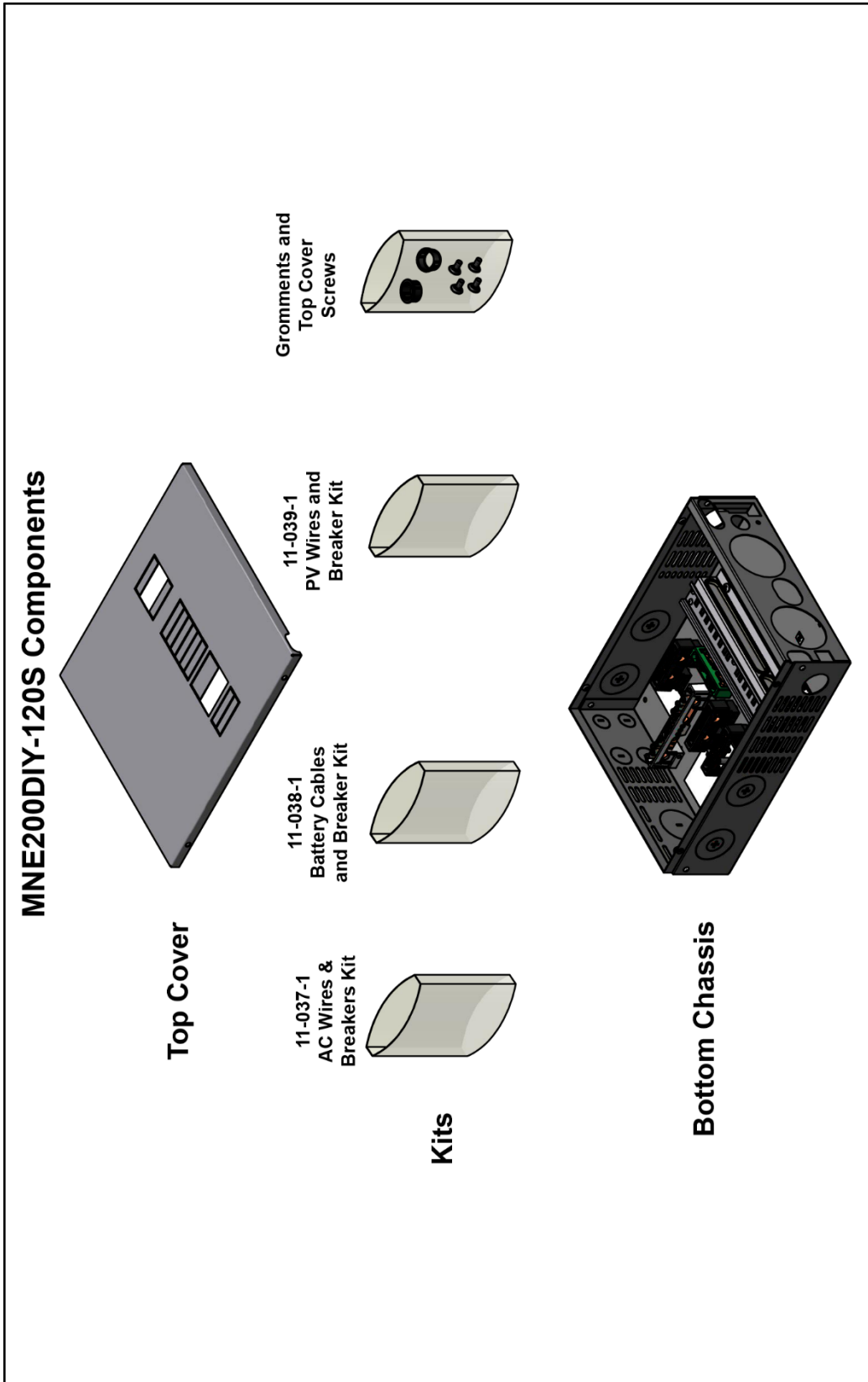

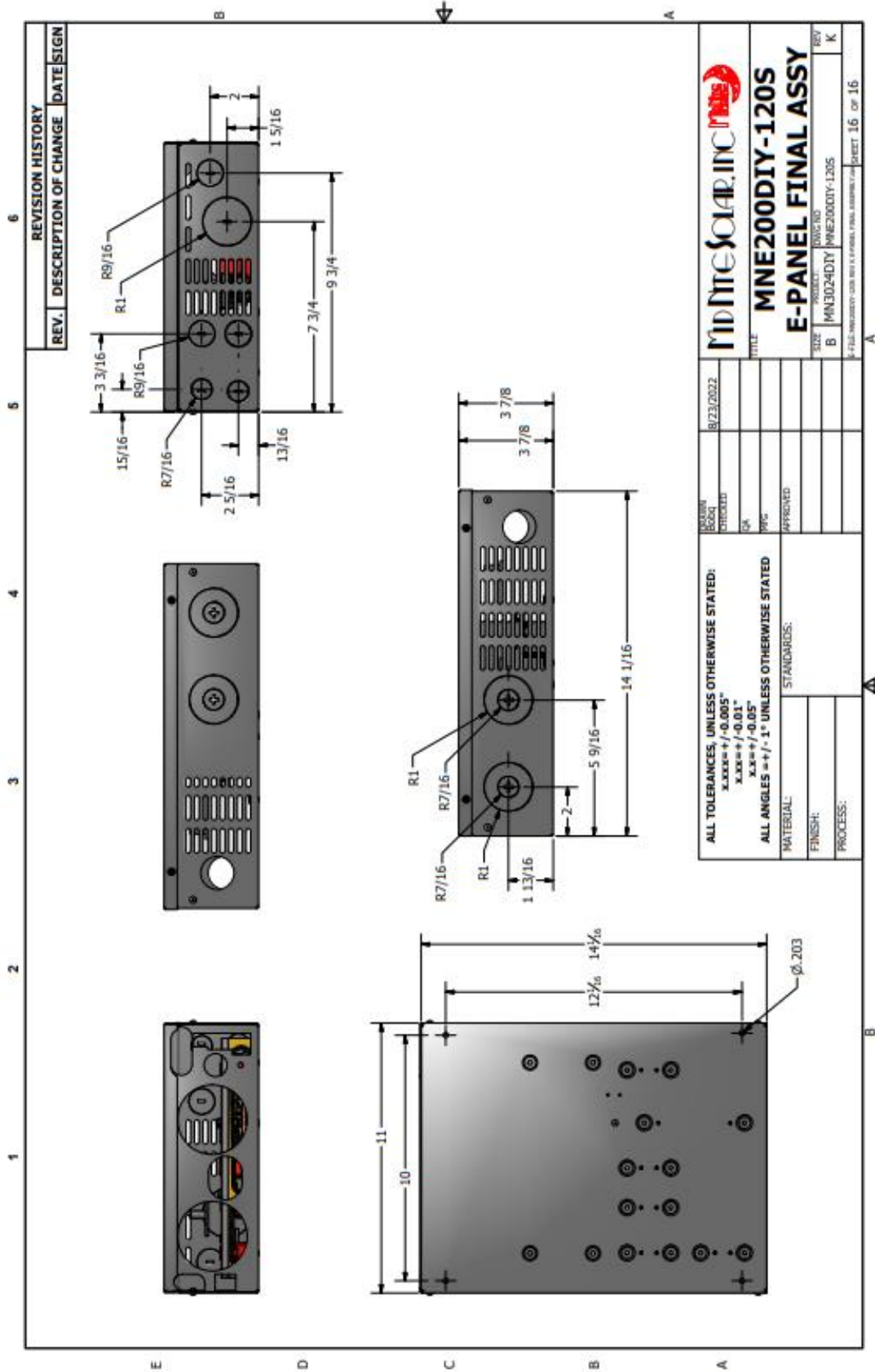

11-037-1P AC Kit Components

AC 01-8G



AC 03-8W and AC 05-8W



AC 06-8B



AC 08-8B



AC 10-8B

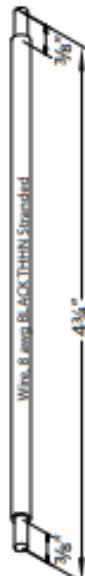

AC 02-8B

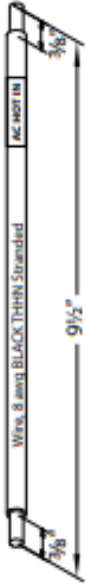

AC 04-8B



AC 07-8B



AC 09-8G



AC INPUT Breaker (40A)



11-038-1P BAT Kit Components

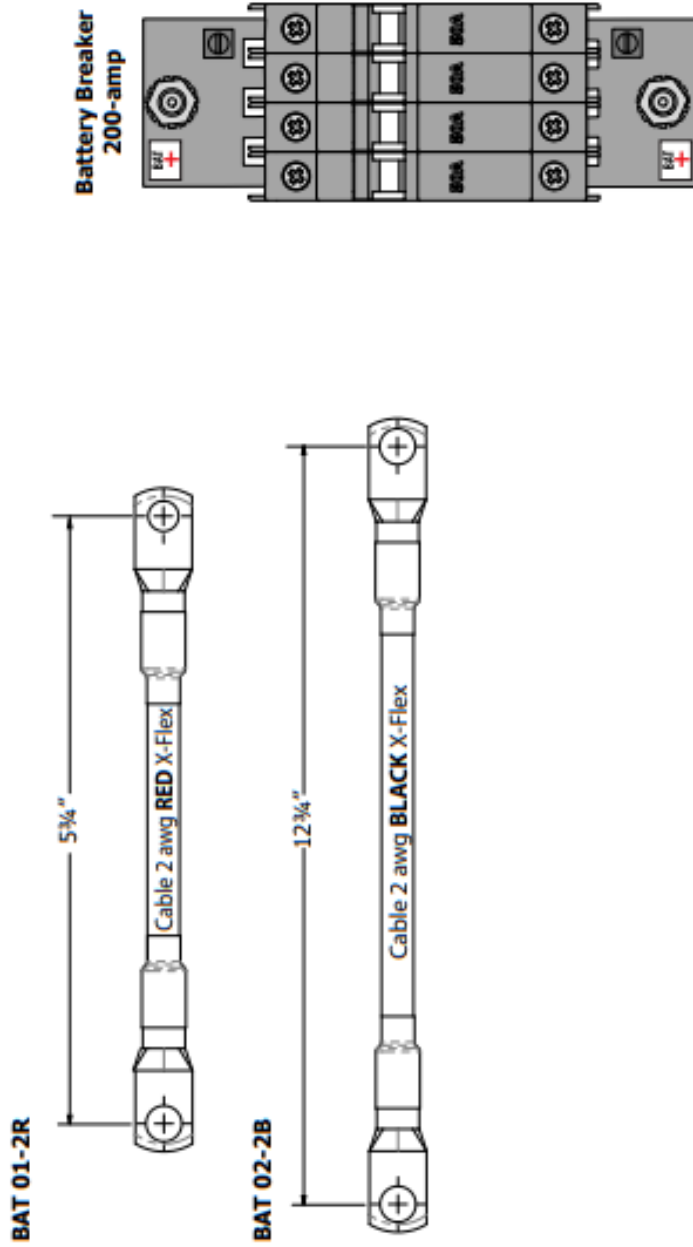

11-038-1P BAT Kit Components (Rev C)

11-039-1P PV Kit Components

PV 01-8R



PV 02-8B

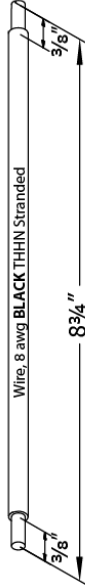

PV 03-8R



PV 04-8B

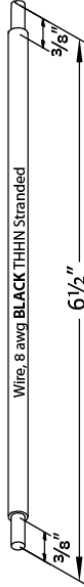

**PV Breaker
(2-pole, 40-amp)**





MNE200DIY-120S Manual

MIDNITE SOLAR INC. LIMITED WARRANTY

MidNite Solar Power electronics, sheet metal enclosures and accessories

MidNite Solar Inc. warrants to the original customer that its products shall be free from defects in materials and workmanship. This warranty will be valid for a period of five (5) years.

MidNite Solar will not warranty third party inverter components used in MidNite's pre-wired systems. Those components are warranted by the original manufacturer.

At its option, MidNite Solar will repair or replace at no charge any MidNite product that proves to be defective within such warranty period. This warranty shall not apply if the MidNite Solar product has been damaged by unreasonable use, accident, negligence, service, or modification by anyone other than MidNite Solar, or by any other causes unrelated to materials and workmanship. The original consumer purchaser must retain original purchase receipt for proof of purchase as a condition precedent to warranty coverage. To receive in-warranty service, the defective product must be received no later than two (2) weeks after the end of the warranty period. The product must be accompanied by proof of purchase and Return Authorization (RA) number issued by MidNite Solar. For an RMA number contact MidNite Solar Inc., (360) 403-7207. Purchasers must prepay all delivery costs or shipping charges to return any defective MidNite Solar product under this warranty policy. Except for the warranty that the products are made in accordance with, the specifications therefore supplied or agreed to by customer:

MIDNITE SOLAR MAKES NO WARRANTY EXPRESSED OR IMPLIED, AND ANY IMPLIED WARRANTY OF MERCHANTABILITY OR FITNESS FOR A PARTICULAR PURPOSE WHICH EXCEEDS THE FOREGOING WARRANTY IS HEREBY DISCLAIMED BY MIDNITE SOLAR AND EXCLUDED FROM ANY AGREEMENT MADE BY ACCEPTANCE OF ANY ORDER PURSUANT TO THIS QUOTATION. MIDNITE SOLAR WILL NOT BE LIABLE FOR ANY CONSEQUENTIAL DAMAGES, LOSS OR EXPENSE ARISING IN CONNECTION WITH THE USE OF OR THE INABILITY TO USE ITS GOODS FOR ANY PURPOSE WHATSOEVER. MIDNITE SOLAR'S MAXIMUM LIABILITY SHALL NOT IN ANY CASE EXCEED THE CONTRACT PRICE FOR THE GOODS CLAIMED TO BE DEFECTIVE OR UNSUITABLE.

Products will be considered accepted by customer unless written notice to the contrary is given to MidNite Solar within ten (10) days of such delivery to customer. MIDNITE SOLAR is not responsible for loss or damage to products owned by customer and located on MIDNITE SOLAR'S premises caused by fire or other casualties beyond MIDNITE SOLAR'S control. This warranty is in lieu of all other warranties expressed or implied.

NOTICE OF COPYRIGHT

MidNite Solar's MNE200DIY-120S E-Panel Owner's Manual

Copyright © 2022 All rights reserved.

MidNite Solar, Inc. reserves the right to revise this document and to periodically make changes to the content hereof without obligation or organization of such revisions or changes unless required to do so by prior arrangement.



MNE200DIY-120S Manual

DISCLAIMER

Unless specifically agreed to in writing, MidNite Solar Inc.: (a) Makes no warranty as to the accuracy, sufficiency, or suitability of any technical or other information provided in its manuals or other documentation; (b) Assumes no responsibility or liability for loss or damage whether direct, indirect, consequential, or incidental, which might arise out of use of such information. The use of any such information will be entirely at the user's risk.

CONTACT

Telephone: 360.403.7207

Email: customerservice@midnitesolar.com

Web: www.midnitesolar.com

